

# HUSHPEEK

## Station Screens



THE  
**ACOUSTICS**  
COMPANY



## PRODUCT INFO

Meet HushPeek, a sleek side desk screen solution that offers versatility to suit your desk configuration. Designed for effortless integration, this screen securely clamps onto your desk, instantly transforming your workspace into a haven of tranquility.

## FEATURES

- Side desk screen made from 12mm recycled PET Panel.
- Available in our collection of 30 vibrant colours.
- Durable, flexible, non-combustible, and easy to customise onsite.
- Great absorptive properties to reduce reverberation.
- Effective sound barrier for increase focus and productivity.
- Easy to install with a desk clamp system.

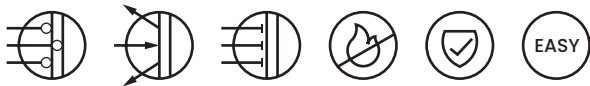

## SIZES

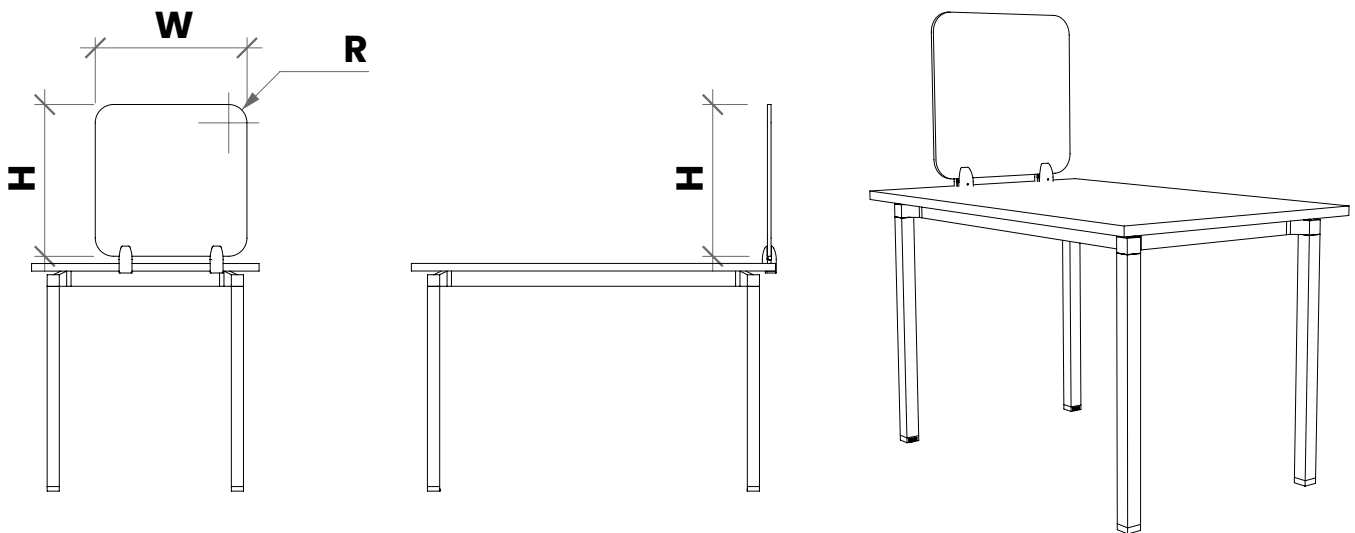

### HEIGHT (H)

385mm  
500mm

### WIDTH (W)

500mm  
600mm  
800mm

### RADIUS (R)

60mm

### PRODUCT

HushPeek

### ARTICLE

05WPSSC-HPK000

### DIMENSION

Modular dimension as shown

### THICKNESS

12mm

# MATERIAL INFORMATION

<b>COMPOSITION:</b>	75% Recycled PET Fibre   25% Virgin Fibre
<b>FIRE RATING:</b>	12mm EN13501-1:2007+A1:2009 B - S1, D0
<b>DENSITY:</b>	2.4kg/m <sup>2</sup> (12mm)
<b>ACOUSTICS:</b>	Class A, C, and D Absorber

\*Our Alpha panels have a Thickness Tolerance of ±1 mm and a Length & Width Tolerance of ±3 mm



## FINISHES

HushPeek is made with high quality recycled PET panels. The selection has different colours that would compliment any interior space and concept. Please refer to the QR code below:



### Finishes

Scan the code or visit  
[www.acousticcompany.com/finishes](http://www.acousticcompany.com/finishes)



### Catalogue

Scan the code or visit  
<https://acousticpanels.co.uk/wp-content/uploads/2025/09/PRODUCT-BROCHURE-2025.pdf>

## INSTALLATION

The Acoustics Company cater for all project budgets and have multiple ways to install a product.

HushPeek station screen can be installed using the following method:

### DESK CLAMP SYSTEM



## DESIGN TIPS

**These are just some design tips you can do in order to maximize the full potential of our HushPeek product:**

1. HushPeek is a complimentary product good for open-plan spaces.
2. Choose colour that compliments the interior of the room.
3. Customise layout and positioning onsite. The easy install feature give you the best option to experiment any creative layout concept.
4. HushPeek is best partnered with HushGaze to create a full modular workstation sanctuary.

## ACOUSTIC PERFORMANCE

The acoustic performance of materials refers to their ability to absorb, reflect, or transmit sound waves. This concept is crucial in architecture, interior design, and engineering, as it determines how sound behaves in a space. Materials with good acoustic performance can reduce noise levels, improve speech intelligibility, and create more comfortable and functional environments by controlling reverberation and sound transmission.

### TESTING STANDARDS

<b>ISO 354</b>	Measurement of sound absorption in a reverberation room
<b>ISO 11654</b>	Sound absorbers for use in buildings – Rating of sound absorption
<b>ASTM C423-17</b>	Standard Test Method for Sound Absorption and Sound Absorption Coefficients by the Reverberation Room Method
<b>ACOUSTICS:</b>	Sound absorbers for use in buildings – Rating of sound absorption

<b>ACOUSTICALLY TESTED</b>	<b>α<sub>w</sub></b>	<b>NRC</b>	<b>CLASS</b>
12mm Direct Fix	0.35(H)	0.45	D
12mm + 75mm Airgap	0.75(MH)	0.85	C
24mm Direct Fix	0.50(MH)	0.65	D
24mm + 75mm Airgap	0.90	1.00	A

For α<sub>w</sub>, it is strongly recommended to use this single- number rating in combination with the complete sound absorption curve that can be obtained on request

<b>FREQUENCY (Hz)</b>	<b>125</b>	<b>250</b>	<b>500</b>	<b>1000</b>	<b>2000</b>	<b>4000</b>
12mm Direct Fix	0.00	0.10	0.30	0.55	0.80	1.00
12mm + 75mm Airgap	0.15	0.45	0.85	1.00	1.00	1.00
24mm Direct Fix	0.05	0.20	0.60	0.85	1.00	1.00
24mm + 75mm Airgap	0.25	0.60	1.00	1.00	1.00	1.00

*Note: The sound absorption values provided in this product sheet are subject to change without prior notice from The Acoustics Company. For the most current and accurate technical specifications, please contact our Sales Team directly.*

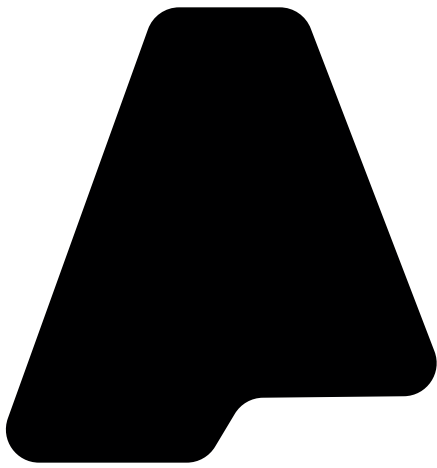

# THE ACOUSTICS COMPANY



[www.acousticscompany.com](http://www.acousticscompany.com)    @theacousticscompany

#ResonateBliss