

MUTEBLEND

Station Screens



THE
ACOUSTICS
COMPANY



PRODUCT INFO

MuteBlend (Variable) is another breakthrough in adaptive workspace solutions that elegantly embraces your table, creating a dynamic visual and acoustic experience. Ingeniously designed as side workstation screen, this product wraps your table at varying pad heights, effortlessly blending form and function.

FEATURES

- Variable Table Wrap made from 12mm recycled PET Panel.
- Available in our collection of 30 vibrant colours.
- Durable, flexible, non-combustible, and easy to customise onsite.
- Great absorptive properties to reduce reverberation.
- Effective sound barrier for increase focus and productivity.
- Easy to install with its free-standing design.

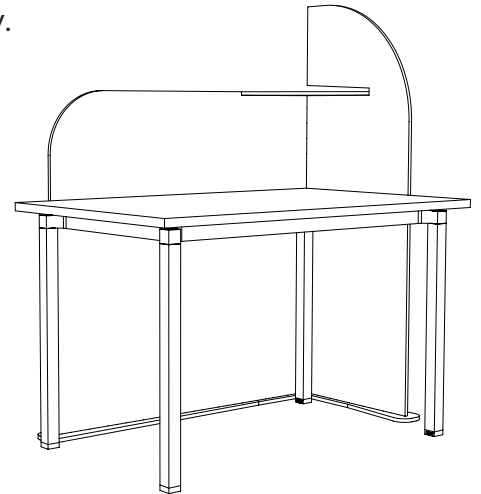
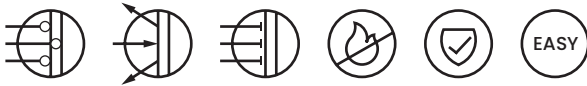

SIZES

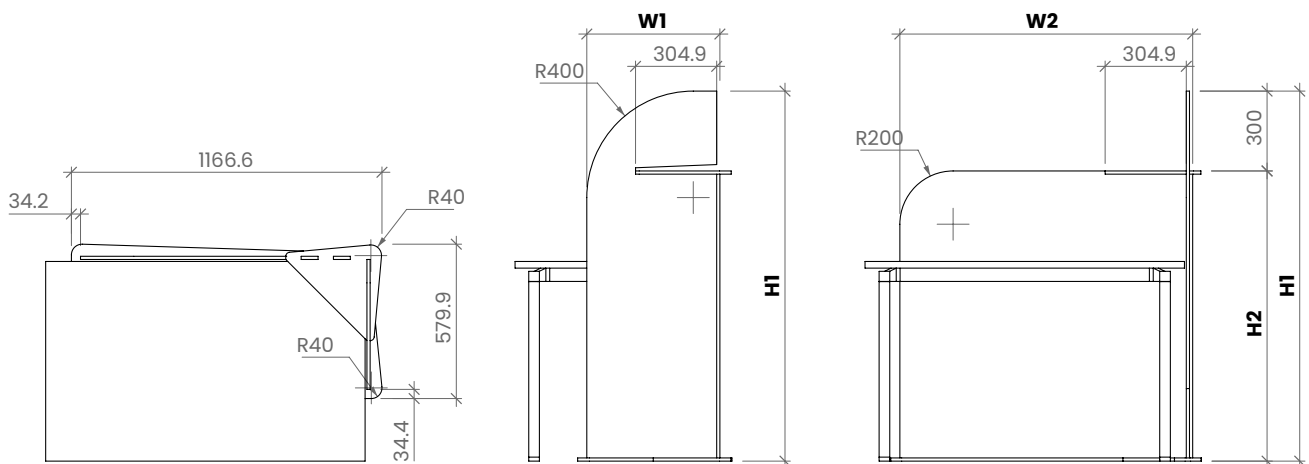

HEIGHT (H1)

1390mm

HEIGHT (H2)

1090mm

PANEL (W1)

500mm

PANEL (W2)

1100mm

PRODUCT	ARTICLE	DIMENSION	THICKNESS
MuteBlend (V)	05WPSSC-MBD001	Modular dimension as shown	12mm



PRODUCT INFO

MuteBlend (Lateral) is another breakthrough in adaptive workspace solutions that elegantly embraces your table, creating a dynamic visual and acoustic experience. Ingeniously designed as side workstation screen, this product wraps your table at equally leveled pad heights, effortlessly blending form and function.

FEATURES

- Level Table Wrap made from 12mm recycled PET Panel.
- Available in our collection of 30 vibrant colours.
- Durable, flexible, non-combustible, and easy to customise onsite.
- Great absorptive properties to reduce reverberation.
- Effective sound barrier for increase focus and productivity.
- Easy to install with its free-standing design.

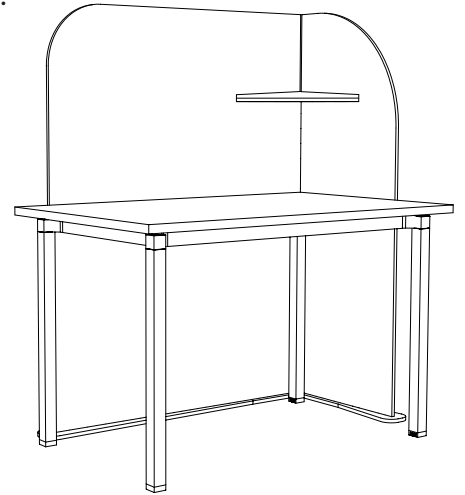
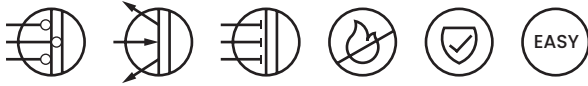

SIZES

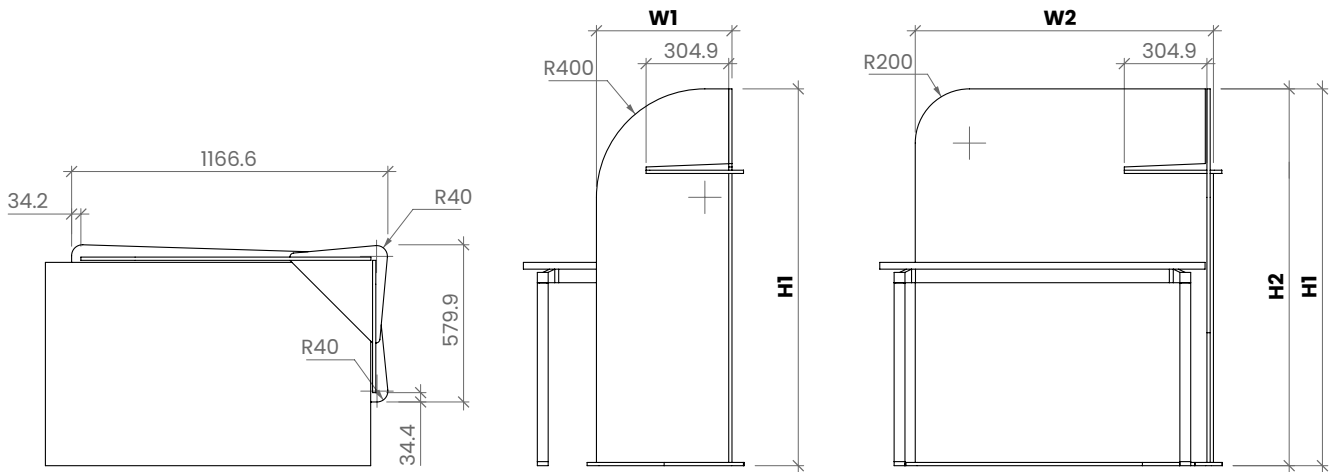

HEIGHT (H1)

1390mm

HEIGHT (H2)

1390mm

PANEL (W1)

500mm

PANEL (W2)

1100mm

PRODUCT	ARTICLE	DIMENSION	THICKNESS
MuteBlend (L)	05WPSSC-MBD002	Modular dimension as shown	12mm

MATERIAL INFORMATION

COMPOSITION:	75% Recycled PET Fibre 25% Virgin Fibre
FIRE RATING:	12mm EN13501-1:2007+A1:2009 B - S1, D0
DENSITY:	2.4kg/m ² (12mm)
ACOUSTICS:	Class A, C, and D Absorber

*Our Alpha panels have a Thickness Tolerance of ±1 mm and a Length & Width Tolerance of ±3 mm



FINISHES

MuteBlend is made with high quality recycled PET panels. The selection has different colours that would compliment any interior space and concept. Please refer to the QR code below:



Finishes
Scan the code or visit
www.acousticcompany.com/finishes



Catalogue
Scan the code or visit
<https://acousticpanels.co.uk/wp-content/uploads/2025/09/PRODUCT-BROCHURE-2025.pdf>

INSTALLATION

The Acoustics Company cater for all project budgets and have multiple ways to install a product.

MuteBlend station screen can be installed using the following method:

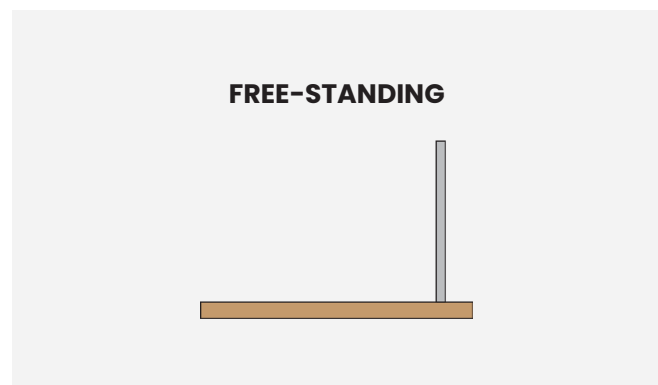

DESIGN TIPS

These are just some design tips you can do in order to maximise the full potential of our MuteBlend products:

1. MuteBlend (Variable) is good for medium offices that needs decent workstation productivity.
2. MuteBlend (Variable) can be arranged side by side with another workstation to create a symmetric room layout design.
3. Choose colour that compliments the interior of the room.
4. MuteBlend (Level) is good for medium offices that needs decent workstation productivity.
5. MuteBlend (Level) can be arranged side by side with another workstation to create a symmetric room layout design.
6. Choose colour that compliments the interior of the room.

ACOUSTIC PERFORMANCE

The acoustic performance of materials refers to their ability to absorb, reflect, or transmit sound waves. This concept is crucial in architecture, interior design, and engineering, as it determines how sound behaves in a space. Materials with good acoustic performance can reduce noise levels, improve speech intelligibility, and create more comfortable and functional environments by controlling reverberation and sound transmission.

TESTING STANDARDS

ISO 354	Measurement of sound absorption in a reverberation room
ISO 11654	Sound absorbers for use in buildings – Rating of sound absorption
ASTM C423-17	Standard Test Method for Sound Absorption and Sound Absorption Coefficients by the Reverberation Room Method
ACOUSTICS:	Sound absorbers for use in buildings – Rating of sound absorption

ACOUSTICALLY TESTED	α_w	NRC	CLASS
12mm Direct Fix	0.35(H)	0.45	D
12mm + 75mm Airgap	0.75(MH)	0.85	C
24mm Direct Fix	0.50(MH)	0.65	D
24mm + 75mm Airgap	0.90	1.00	A

For α_w, it is strongly recommended to use this single- number rating in combination with the complete sound absorption curve that can be obtained on request

FREQUENCY (Hz)	125	250	500	1000	2000	4000
12mm Direct Fix	0.00	0.10	0.30	0.55	0.80	1.00
12mm + 75mm Airgap	0.15	0.45	0.85	1.00	1.00	1.00
24mm Direct Fix	0.05	0.20	0.60	0.85	1.00	1.00
24mm + 75mm Airgap	0.25	0.60	1.00	1.00	1.00	1.00

Note: The sound absorption values provided in this product sheet are subject to change without prior notice from The Acoustics Company. For the most current and accurate technical specifications, please contact our Sales Team directly.

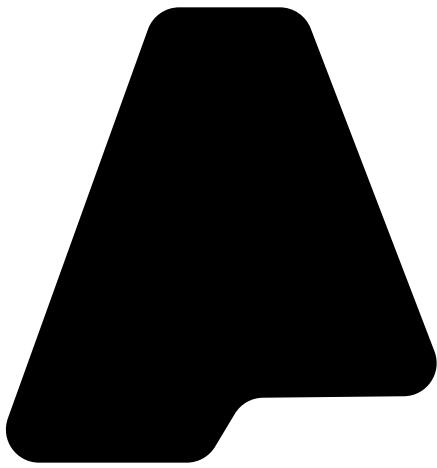

THE ACOUSTICS COMPANY



www.acousticscompany.com [f](#) [@](#) [in](#) @theacousticscompany

#ResonateBliss