



THE
ACOUSTICS
COMPANY

GLOW

Pendent Lighting



PRODUCT INFO

Acoustic lighting seamlessly blends innovative design with functionality, addressing both lighting and acoustic requirements. Introducing Glow, a versatile and contemporary pendant crafted from recycled PET materials. Designed to be suspended like a traditional pendant, Glow integrates effortlessly into any interior setting and comes in a variety of shapes and sizes to suit diverse design needs.

Illuminate your space with Glow, an acoustic lighting solution that is not only easy to install but also elegantly efficient.

Product Notes:

- **Fixing:** Glow is supplied with the shade only. No light or light fixtures are supplied with this product.
- **Frame and Diffuser:** As standard Glow is supplied with a white frame and white diffuser. Please contact the sales team to discuss alternatives.

GLOW DESIGNS

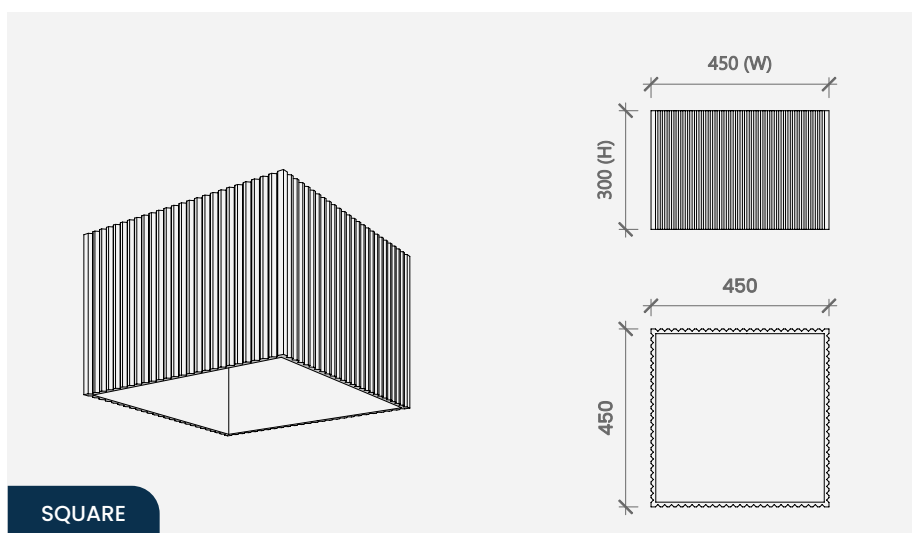
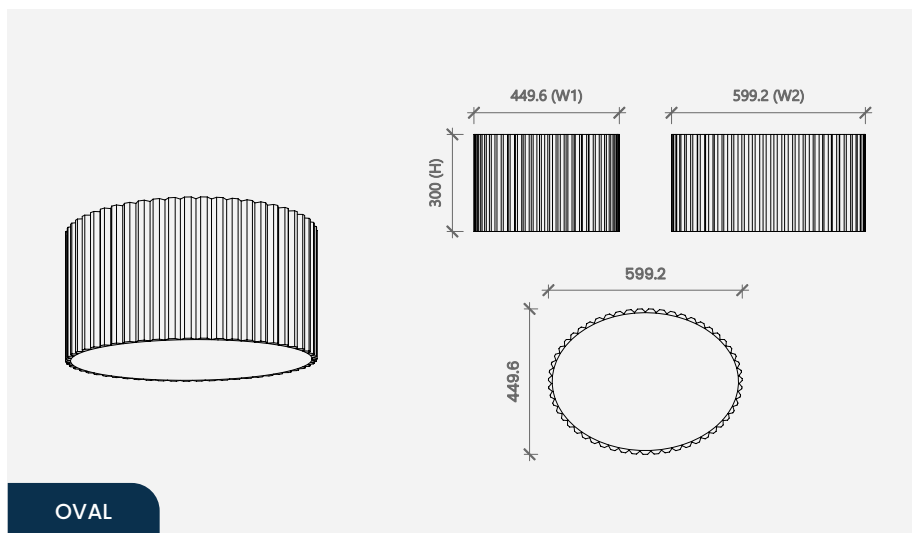
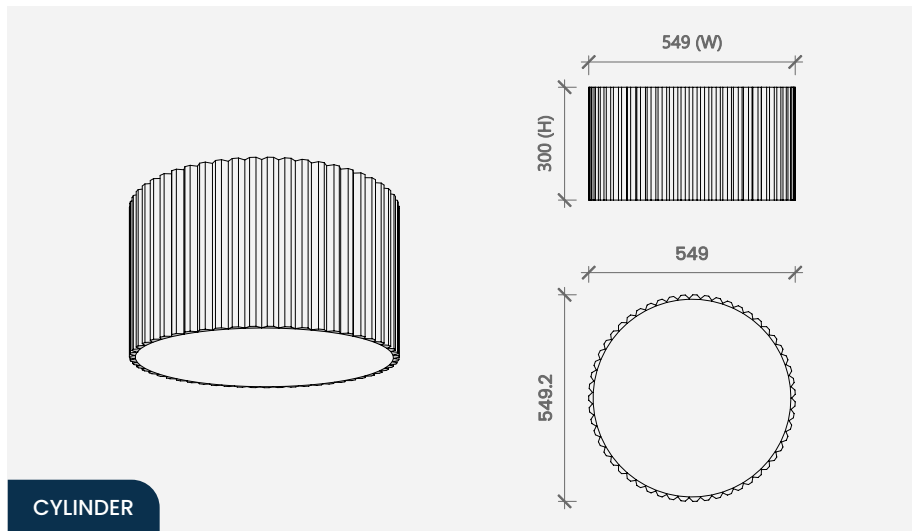

PRODUCT	ARTICLE	DIMENSION	THICKNESS
Cylinder	07ALGLO-CYL000	549mm x 300mm	12mm
Oval	07ALGLO-OVA000	449.6mm x 599.2mm x 300mm	12mm
Square	07ALGLO-SQU000	450mm x 300mm	12mm

MATERIAL INFORMATION

COMPOSITION:	75% Recycled PET Fibre 25% Virgin Fibre
FIRE RATING:	12mm EN13501-1:2007+A1:2009 B - S1, D0
DENSITY:	2.4kg/m ² (12mm)
ACOUSTICS:	Class A, C, and D Absorber

*Our Alpha panels have a Thickness Tolerance of ±1 mm and a Length & Width Tolerance of ±3 mm



FINISHES

Glow is made with high quality recycled PET panels. The selection has different colours that would compliment any interior space and concept. See finishes on the following links:



Finishes
Scan the code or visit
www.acousticcompany.com/finishes



Catalogue
Scan the code or visit
<https://acousticpanels.co.uk/wp-content/uploads/2025/09/PRODUCT-BROCHURE-2025.pdf>

DESIGN TIPS

Design tips you can do to maximize the full potential of our Glow products:

1. Install Glow pendants in soft, organic shapes, above dining tables or kitchen islands.
2. Suspend Glow pendants in bold, geometric shapes from high ceilings in loft spaces or converted warehouses.
3. Accent Glow with natural materials like stone or wood flooring to create a serene and clutter-free environment. Ideal for open-plan living rooms, modern offices, or gallery spaces where simplicity and sound control are key.
4. Incorporate Glow with metal accents in furniture or light fixtures, alongside rugged leather seating, to create a dynamic visual and acoustic balance ideal for trendy restaurants, creative workspaces, or urban living areas where industrial elements meet modern design solutions.

ACOUSTIC PERFORMANCE

The acoustic performance of materials refers to their ability to absorb, reflect, or transmit sound waves. This concept is crucial in architecture, interior design, and engineering, as it determines how sound behaves in a space. Materials with good acoustic performance can reduce noise levels, improve speech intelligibility, and create more comfortable and functional environments by controlling reverberation and sound transmission.

TESTING STANDARDS

ISO 354	Measurement of sound absorption in a reverberation room
ISO 11654	Sound absorbers for use in buildings – Rating of sound absorption
ASTM C423-17	Standard Test Method for Sound Absorption and Sound Absorption Coefficients by the Reverberation Room Method
ACOUSTICS:	Sound absorbers for use in buildings – Rating of sound absorption

ACOUSTICALLY TESTED	α_w	NRC	CLASS
12mm Direct Fix	0.35(H)	0.45	D
12mm + 75mm Airgap	0.75(MH)	0.85	C
24mm Direct Fix	0.50(MH)	0.65	D
24mm + 75mm Airgap	0.90	1.00	A

For α_w, it is strongly recommended to use this single- number rating in combination with the complete sound absorption curve that can be obtained on request

FREQUENCY (Hz)	125	250	500	1000	2000	4000
12mm Direct Fix	0.00	0.10	0.30	0.55	0.80	1.00
12mm + 75mm Airgap	0.15	0.45	0.85	1.00	1.00	1.00
24mm Direct Fix	0.05	0.20	0.60	0.85	1.00	1.00
24mm + 75mm Airgap	0.25	0.60	1.00	1.00	1.00	1.00

Note: The sound absorption values provided in this product sheet are subject to change without prior notice from The Acoustics Company. For the most current and accurate technical specifications, please contact our Sales Team directly.

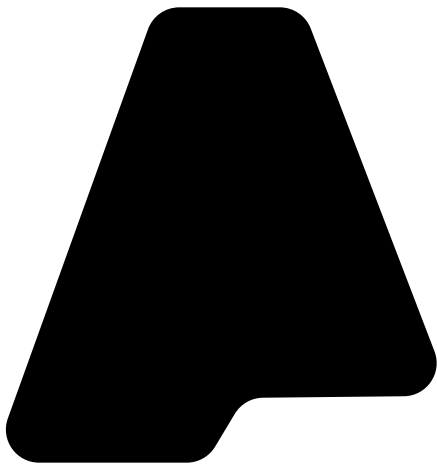

THE ACOUSTICS COMPANY



www.acousticscompany.com    @theacousticscompany

#ResonateBliss