



THE  
**ACOUSTICS**  
COMPANY



# Reverb

Acoustic ceiling raft system

---

# Reverb

in Application



*Designed to integrate seamlessly within architectural environments, delivering high-performance acoustic control with clarity in specification.*

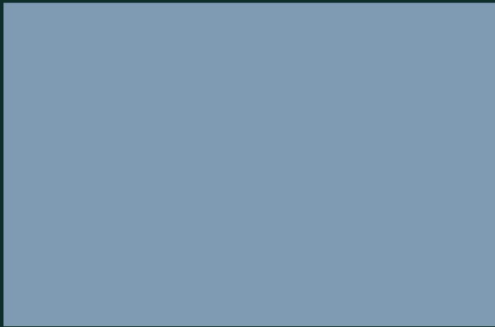

Telford, UK  
Le Lude, FR

+44 (0)1952 947390  
sales@acousticscompany.com

www.acousticscompany.com  
www.acousticscompany.fr

**Design** with confidence  
**Specify** with clarity.

p.2



THE  
**ACOUSTICS**  
COMPANY

# Technical

# Reverb Panel™

## Material Datasheet

<b>Product Name</b>	Reverb Panel™
<b>Composition</b>	High-density glass wool Manufactured with 54% recycled glass fibre content
<b>Thickness</b> <sup>1</sup>	40 mm (0.47")
<b>Density</b>	120 kg/m <sup>2</sup>
<b>Acoustic</b> <sup>3</sup>	$\alpha_w = 0.95$ (MH) NRC 0.95
<b>Finishes</b> <sup>2</sup>	Supplied in White; Other finishes available subject to MOQ and extended lead times; Colours available for larger custom projects (12+ week lead time); Custom panel sizes available (12+ week min. lead time)
<b>Fire Rating</b>	Class B-s1,d0 (EN 13501-1) Low smoke, No flaming droplets
<b>VOC Emissions</b>	E1 classification <b>Formaldehyde:</b> 0.1 mg/L – E1 classification <b>TVOC:</b> <0.01 mg/m <sup>3</sup> <b>Benzene:</b> Not detected <b>Toluene:</b> 0.02 mg/m <sup>3</sup> <b>Xylene:</b> Not detected
<b>Durability</b> <sup>5</sup>	Hygienic and mould-resistant
<b>Tolerances</b>	Thickness: ±1–2mm Length/Width: ±3–5mm
<b>Shapes Sizes</b>	1800 × 1200 × 40mm 2400 × 1200 × 40mm Ø1200 × 40mm Ø1000 × 40mm Ø800 × 40mm 1200 × 1200 × 40mm 1200 × 600 × 40mm

1 - all values are nominal

2 - product is customizable on a typical 15 week leadtime

3 - tested with 100 mm airgap

4 - this applies to standard products that have been installed without adhesives

5 - relates to core material

6 - core only, fabrics not considered



Telford, UK  
Le Lude, FR

+44 (0)1952 947390  
sales@acousticscompany.com

www.acousticscompany.com  
www.acousticscompany.fr

**Design** with confidence  
**Specify** with clarity.



# Reverb Panel™

## Finishes

**Standard Colour Option:** Grey White

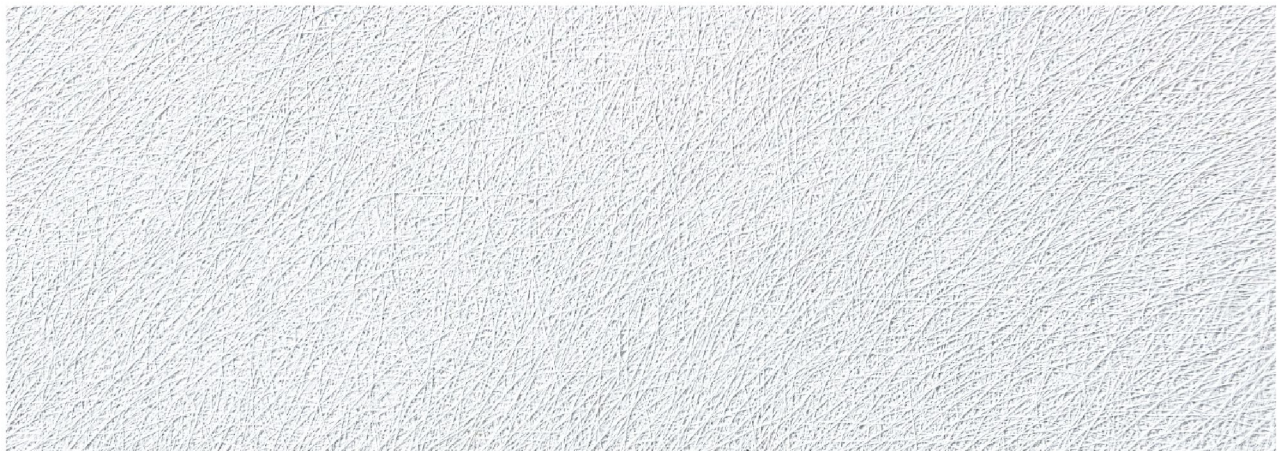

**Custom Colours Available:**

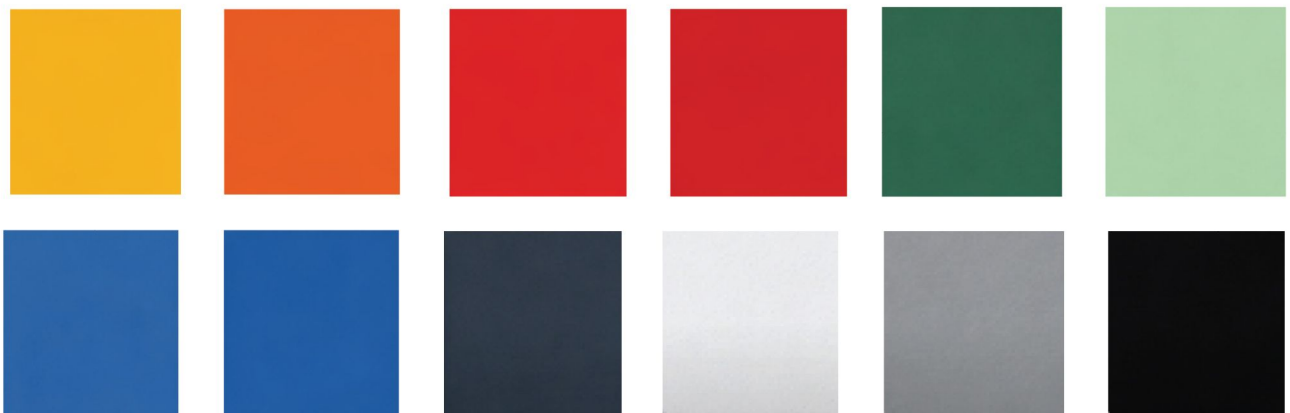

Bespoke RAL colour matching is available for larger projects. Manufacturing lead time is typically 12-15 weeks; colour matching and final confirmation may extend overall lead times.



Telford, UK  
Le Lude, FR

+44 (0)1952 947390  
sales@acousticscompany.com

www.acousticscompany.com  
www.acousticscompany.fr

**Design** with confidence  
**Specify** with clarity.

# Reverb Panel™

## Acoustic Data

The acoustic performance of materials refers to their ability to absorb, reflect, or transmit sound waves. This concept is crucial in architecture, interior design, and engineering, as it determines how sound behaves in a space. Materials with good acoustic performance can reduce noise levels, improve speech intelligibility, and create more comfortable and functional environments by controlling reverberation and sound transmission.

### TESTING STANDARDS

(all values extracted from certified test results.)

<b>ISO 354</b>	Measurement of sound absorption in a reverberation room
<b>ISO 11654</b>	Sound absorbers for use in buildings – Rating of Sound Absorption
<b>ASTM C423</b>	Standard Test Method for sound absorption and sound absorption coefficients by the reverberation room method
<b>ACOUSTICS:</b>	Sound absorbers for use in buildings – Rating of sound absorption

<b>ACOUSTICALLY TESTED</b>	<b>aw</b>	<b>NRC</b>	<b>CLASS</b>
	0.95	0.95	A

For aw, it is strongly recommended to use this single-number rating in combination with the complete sound absorption.

<b>FREQUENCY (Hz)</b>	<b>125</b>	<b>250</b>	<b>500</b>	<b>1000</b>	<b>2000</b>	<b>4000</b>
Absorption (ai)	0.25	0.60	0.90	0.95	0.95	1.00

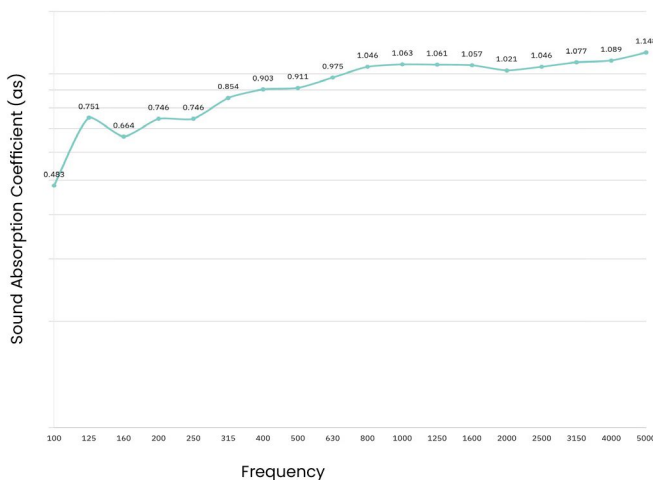

**Weighted Sound Absorption Coefficient (aw)** - Measured in accordance with ISO 11654. Practical sound absorption coefficient ap values at given standard frequencies are compared with reference curve aw.

**Noise Reduction Coefficient (NRC)** - The mean average as value at frequencies 250, 500, 1000 and 2000 Hz.

**Absorption Class** - Levels of comparison of absorption values against a reference curve with A as highest and E as lowest. Measured in accordance with ISO 11654.

**Practical Sound Absorption Coefficient (ap)** - The average of the three as values centered on the 1/3 octave band center frequency, measured in accordance with EN ISO 354.



Le Lude, FR  
Telford, UK

+44 (0)1952 947390  
sales@acousticscompany.com

www.acousticscompany.com  
www.acousticscompany.fr

**Design** with confidence  
**Specify** with clarity.

*Developed to simplify acoustic design and specification, ensuring clarity, coordination, and confidence throughout the project.*

**Design** with confidence. **Specify** with clarity.

# Path to Specification

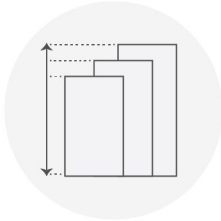

## 1. SIZE AND LAYOUT

Review available sizes, layouts and configuration options.

*pages 10-12*

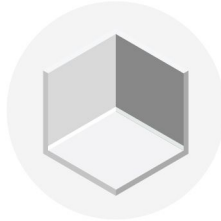

## 2. SPACE

Understand where the product is used and the key spatial constraints.

*pages 14-16*

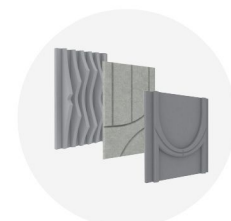

## 3. DESIGN

Explore design options to achieve the desired aesthetic.

*page 19*



## 4. DETAIL

Consider how the system integrates with building elements and site.

*page 20*

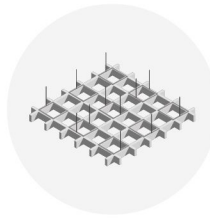

## 6. INSTALLATION

Define the appropriate fixing and installation method.

*pages 22-37*



## 8. AFTERCARE

Understand cleaning, care and long-term maintenance.

*pages 39-40*



Telford, UK  
Le Lude, FR

+44 (0)1952 947390  
sales@acousticscompany.com

www.acousticscompany.com  
www.acousticscompany.fr

**Design** with confidence  
**Specify** with clarity.

p.8

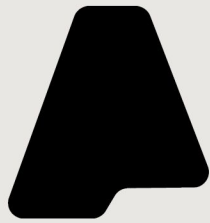

THE  
**ACOUSTICS**  
COMPANY

# Size & Layout

# Size and Layout

## Circle

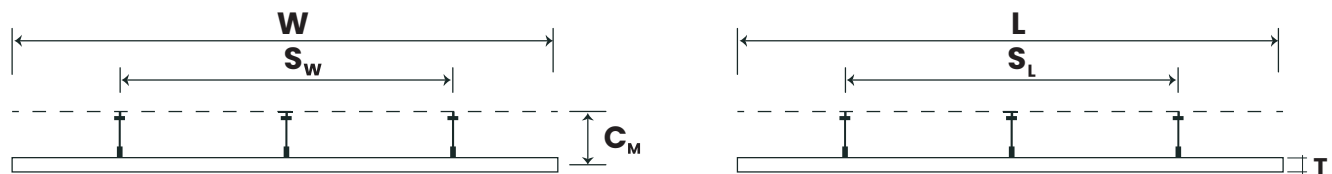
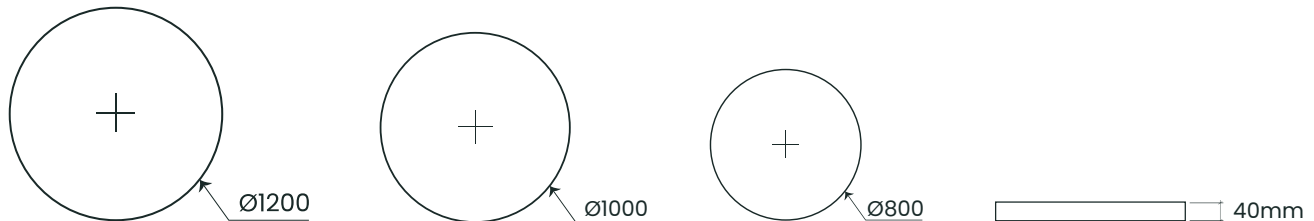

### Dimension Table

<b>W</b>	<b>Total Width</b>	1200	1000	800
<b>L</b>	<b>Total Length</b>	1200	1000	800
	<b>Area m<sup>2</sup></b>	1.13m <sup>2</sup>	.79m <sup>2</sup>	.50m <sup>2</sup>
	<b>Weight</b>	5.43 kg	3.77 kg	2.41 kg
<b>C<sub>M</sub></b>	<b>Distance from ceiling</b>	min 100mm		
<b>S<sub>w</sub></b>	<b>Support spacing W</b>	800mm	600mm	400mm
<b>S<sub>L</sub></b>	<b>Support spacing L</b>	800mm	600mm	400mm
	<b>Number of Fixings</b>	3		
	<b>Type of Fixings</b>	Ambiance Fixing		
<b>T</b>	<b>Material Thickness</b>	40mm		



# Rectangle

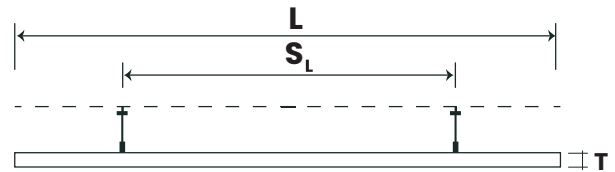
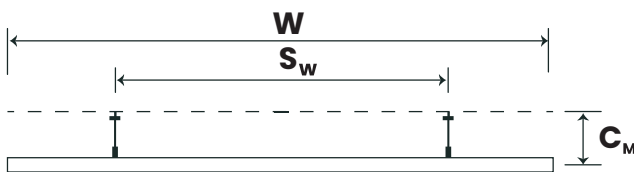
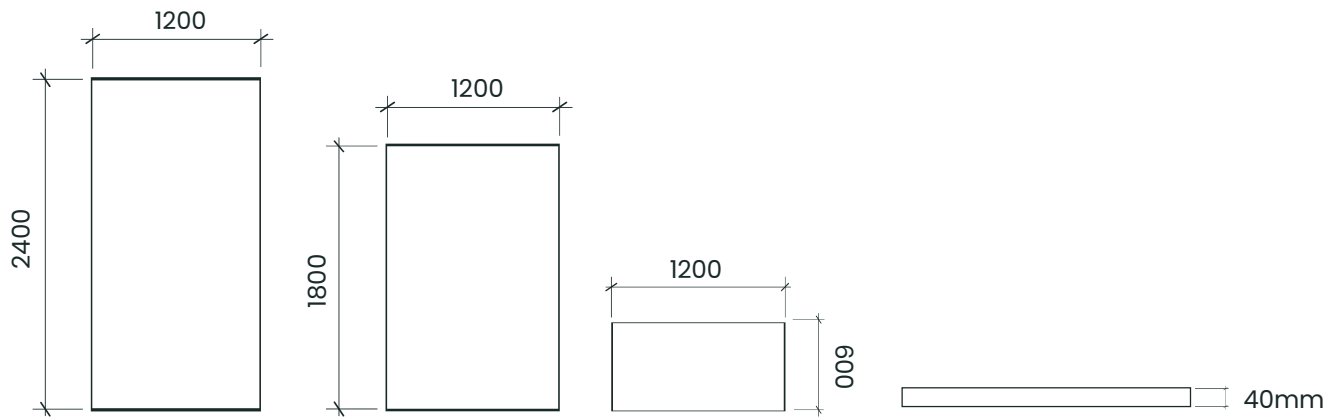

## Dimension Table

<b>W</b>	<b>Total Width</b>	1200	1200	1200
<b>L</b>	<b>Total Length</b>	2400	1800	600
	<b>Area m<sup>2</sup></b>	2.88m <sup>2</sup>	2.16m <sup>2</sup>	0.72m <sup>2</sup>
	<b>Weight</b>	13.82 kg	10.37 kg	3.46 kg
<b>C<sub>M</sub></b>	<b>Distance from ceiling</b>	min 100mm		
<b>S<sub>W</sub></b>	<b>Support spacing W</b>	800mm	800mm	200mm
<b>S<sub>L</sub></b>	<b>Support spacing L</b>	666mm	1400mm	800mm
	<b>Number of Fixings</b>	6	4	4
	<b>Type of Fixings</b>	Ambiance Fixing		
<b>T</b>	<b>Material Thickness</b>	40mm		



# Square

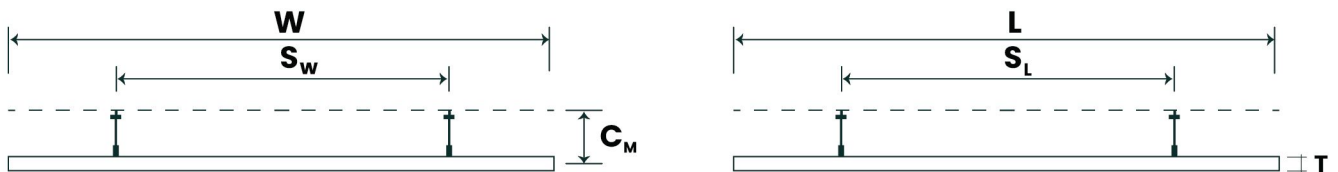
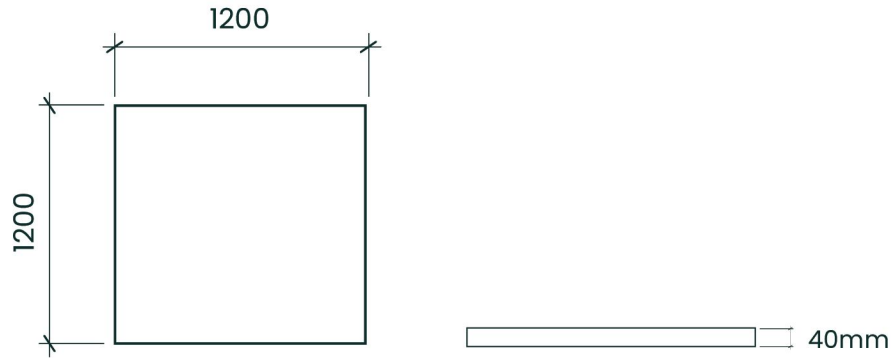

## Dimension Table

<b>W</b>	<b>Total Width</b>	1200
<b>L</b>	<b>Total Length</b>	1200
	<b>Area m<sup>2</sup></b>	1.44m <sup>2</sup>
	<b>Weight</b>	6.91 kg
<b>C<sub>M</sub></b>	<b>Distance from ceiling</b>	min 100mm
<b>S<sub>w</sub></b>	<b>Support spacing W</b>	800mm
<b>S<sub>L</sub></b>	<b>Support spacing L</b>	800mm
	<b>Number of Fixings</b>	4
	<b>Type of Fixings</b>	Ambiance Fixing
<b>T</b>	<b>Material Thickness</b>	40mm



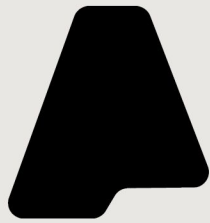

THE  
**ACOUSTICS**  
COMPANY

**Space**

# Space

---

These visuals demonstrate how Reverb can be strategically applied to control acoustics, define space, and integrate seamlessly within architectural layouts.



## **Breakout/Informal Area**

Breakout and informal areas are social, multi-use spaces designed for collaboration and relaxation. Acoustic rafts should be positioned above seating zones to control reverberation and reduce background noise, while maintaining an open and comfortable environment.



## **Circulation / Pathways**

Circulation areas connect key parts of a building and require careful acoustic control. Rafts should be positioned above primary pathways to manage sound transfer while maintaining clear movement routes, access, and visibility.





## Zoning Within Large Spaces

In open-plan environments, rafts should be used to define functional zones without the need for physical partitions. Positioned above key areas, they create visual structure, improve acoustic performance, and support flexible, well-balanced workspace layouts.



## Reception Area

Reception areas form the first impression of a space and require both acoustic control and visual clarity. Rafts should be positioned above desks and waiting zones to enhance speech clarity while contributing to a clean, considered ceiling composition.



## Open Plan Environment

Open-plan environments combine multiple activities within a single space. Rafts should be arranged in coordination with lighting and services to control overall noise levels, ensuring a balanced, comfortable, and acoustically effective workspace.





### **Meeting/Collaboration Spaces**

Meeting and collaboration spaces require controlled acoustic conditions to support clear communication. Rafts should be positioned directly above tables or central zones to reduce sound reflection and improve speech clarity.



### **Double height / Open Soffit**

In double-height or open soffit environments, rafts should be suspended within the exposed ceiling to control acoustics in larger volumes. This approach maintains the architectural intent while improving overall acoustic performance.



Telford, UK  
Le Lude, FR

+44 (0)1952 947390  
sales@acousticscompany.com

www.acousticscompany.com  
www.acousticscompany.fr

**Design** with confidence  
**Specify** with clarity.



# Design

# Design Recommendations

---

**Coordinate early** – Develop panel layouts alongside lighting and M&E services to avoid clashes and redesign later in the project.

**Align with key elements** – Set out panels in relation to lighting, grids, and architectural features.

**Maintain consistency** – Use consistent spacing and alignment to achieve a clean and considered ceiling layout.

**Allow for access** – Ensure access to services is maintained without compromising design intent.

**Confirm ceiling build-up** – Review ceiling void depth early to accommodate suspension and integration.

**Consider visual balance** – Adjust panel quantity and spacing to suit the scale and proportion of the space.





# Detail

# Detail Considerations

---

**M&E coordination** – Align panel layout with lighting, sprinklers, HVAC and other ceiling services to maintain both performance and visual consistency.

**Fixing point availability** – Confirm fixing zones within the ceiling structure early to avoid clashes and ensure feasibility.

**Ceiling substrate suitability** – Assess substrate type, condition and build-up to ensure it can support the system and fixing method.

**Suspension heights** – Coordinate suspension levels with ceiling datum, services and adjacent elements for a consistent visual plane.

**Lighting and services integration** – Plan panel positions in relation to lighting layouts and service zones to maintain alignment and avoid disruption.

**Access for maintenance** – Ensure panels can be removed or adjusted to allow access to services above.

**Load requirements** – Verify structural loading capacity, particularly for larger or repeated installations.

**Fixing tolerances** – Allow for site tolerances to maintain alignment, spacing and overall visual quality.



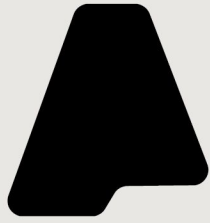

THE  
**ACOUSTICS**  
COMPANY

# Installation

# Reverb Rectangle

Ceiling Rafts

**Installation Guide** using Spiral Fixing

---

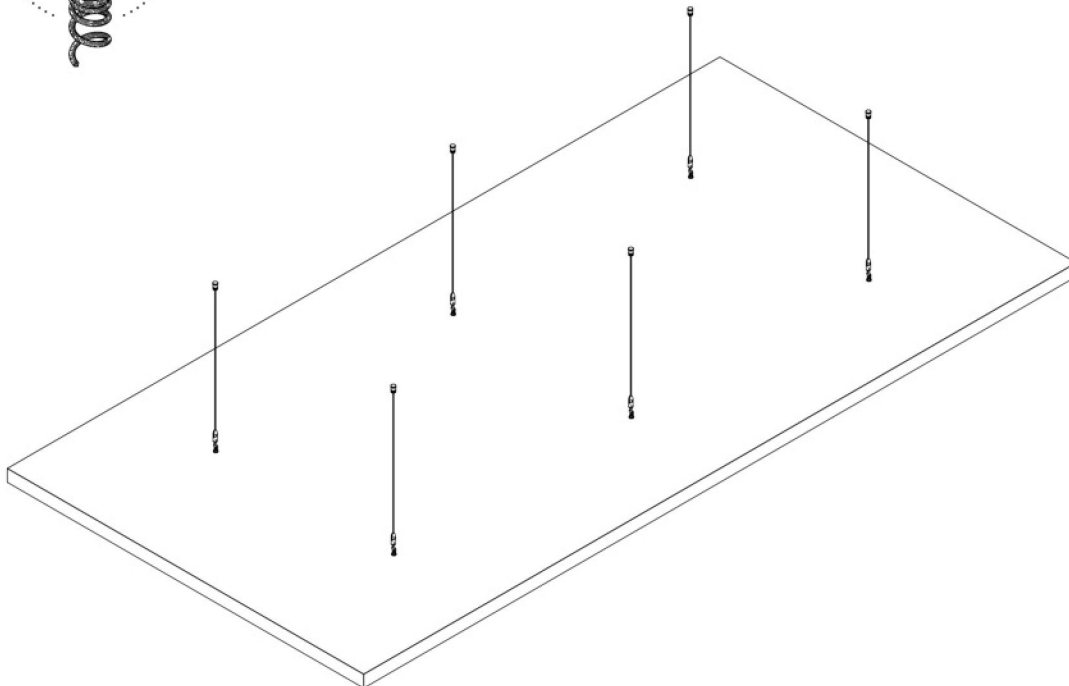
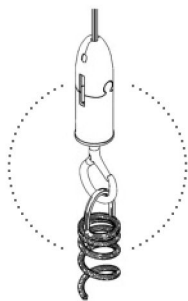

Telford, UK  
Le Lude, FR

+44 (0)1952 947390  
sales@acousticscompany.com

www.acousticscompany.com  
www.acousticscompany.fr

**Design** with confidence  
**Specify** with clarity. p.22

# Reverb Rectangle

The provided installation guide is intended for general use and is designed to support skilled tradespeople.

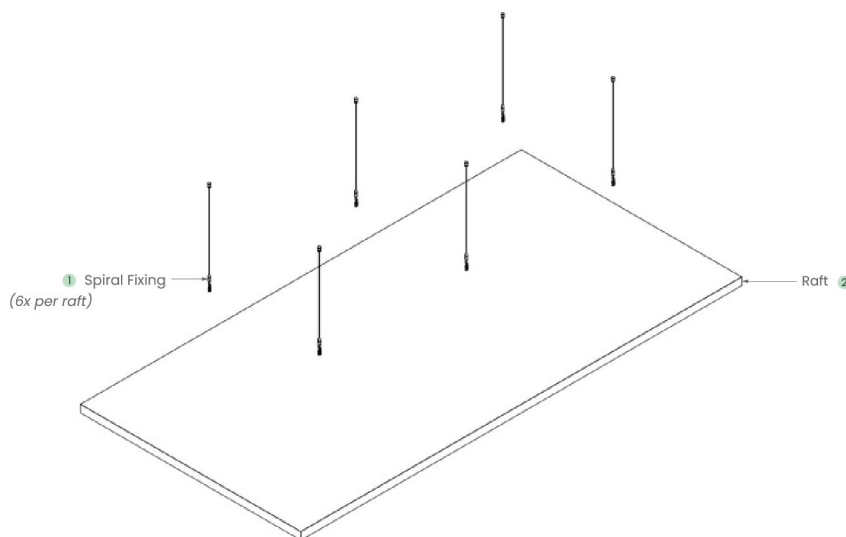

## 1

### Fixing Points

Note: Recommended positions, site specific / additional points to be determined by installer.

### Fixings

Disclaimer: Suitable / additional fixings for substrate to be determined by installer.

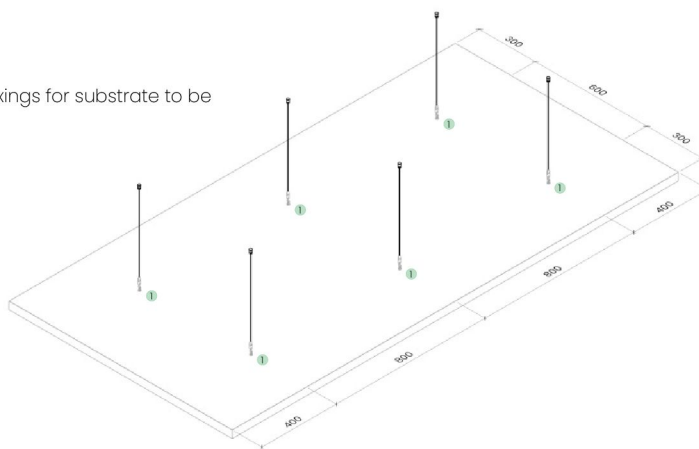

Telford, UK  
Le Lude, FR

+44 (0)1952 947390  
sales@acousticscompany.com

www.acousticscompany.com  
www.acousticscompany.fr

**Design** with confidence  
**Specify** with clarity.

p.23

# Reverb Rectangle

The provided installation guide is intended for general use and is designed to support skilled tradespeople.

2

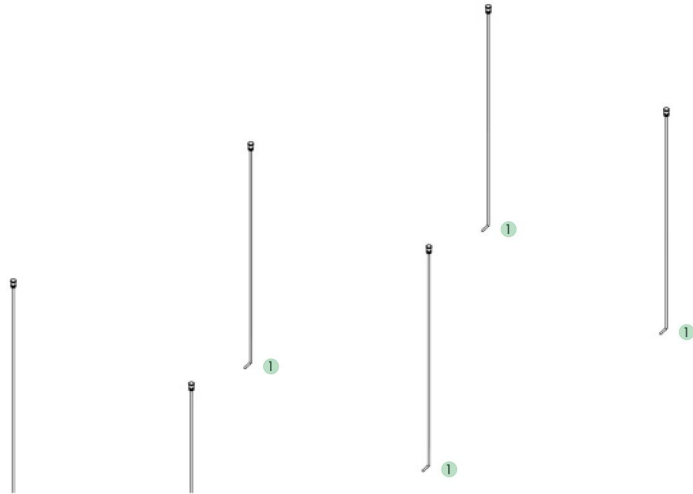

3

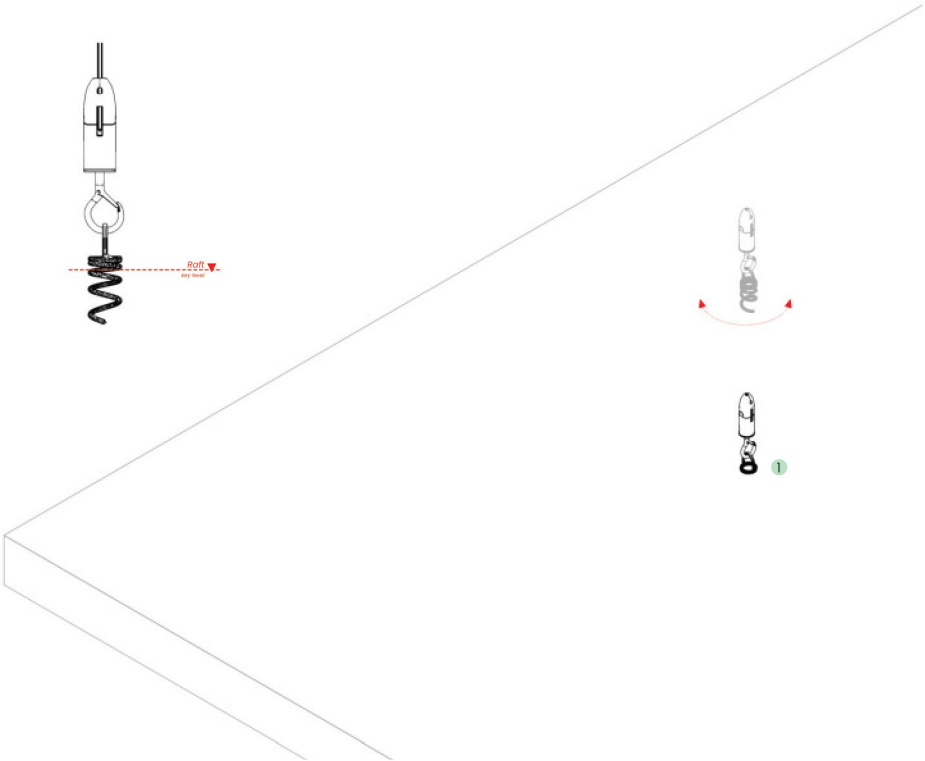

Telford, UK  
Le Lude, FR

+44 (0)1952 947390  
sales@acousticscompany.com

www.acousticscompany.com  
www.acousticscompany.fr

**Design** with confidence  
**Specify** with clarity. p.24

# Reverb Rectangle

The provided installation guide is intended for general use and is designed to support skilled tradespeople.

---

4

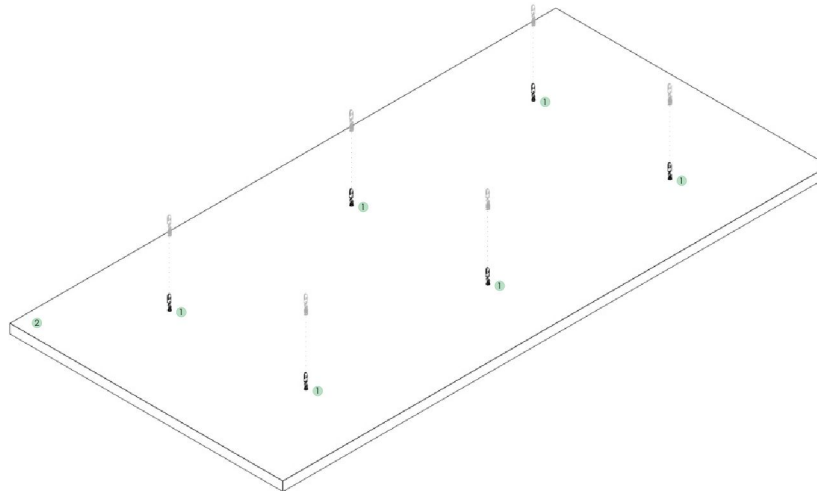

5

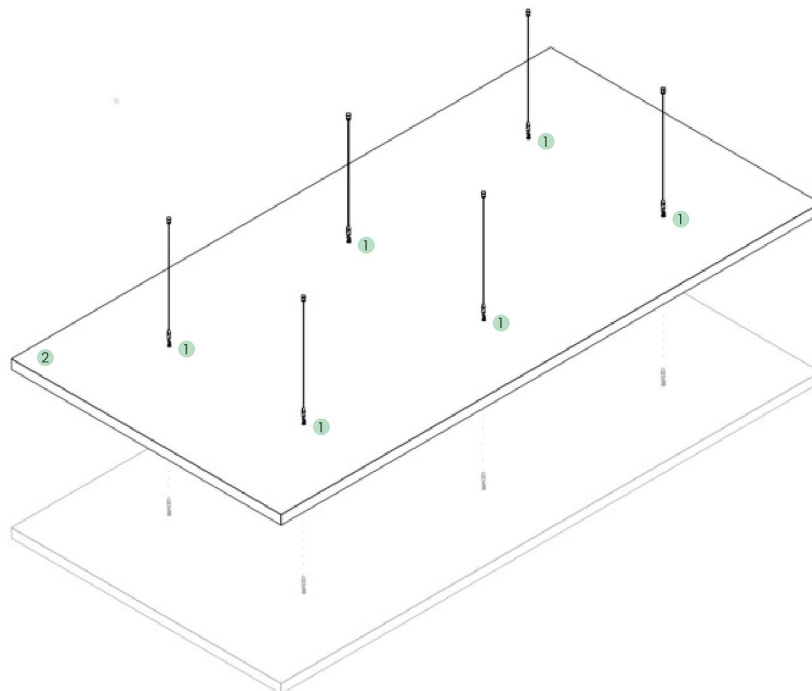

Telford, UK  
Le Lude, FR

+44 (0)1952 947390  
sales@acousticscompany.com

www.acousticscompany.com  
www.acousticscompany.fr

**Design** with confidence  
**Specify** with clarity. p.25

# Reverb Rectangle

The provided installation guide is intended for general use and is designed to support skilled tradespeople.

---

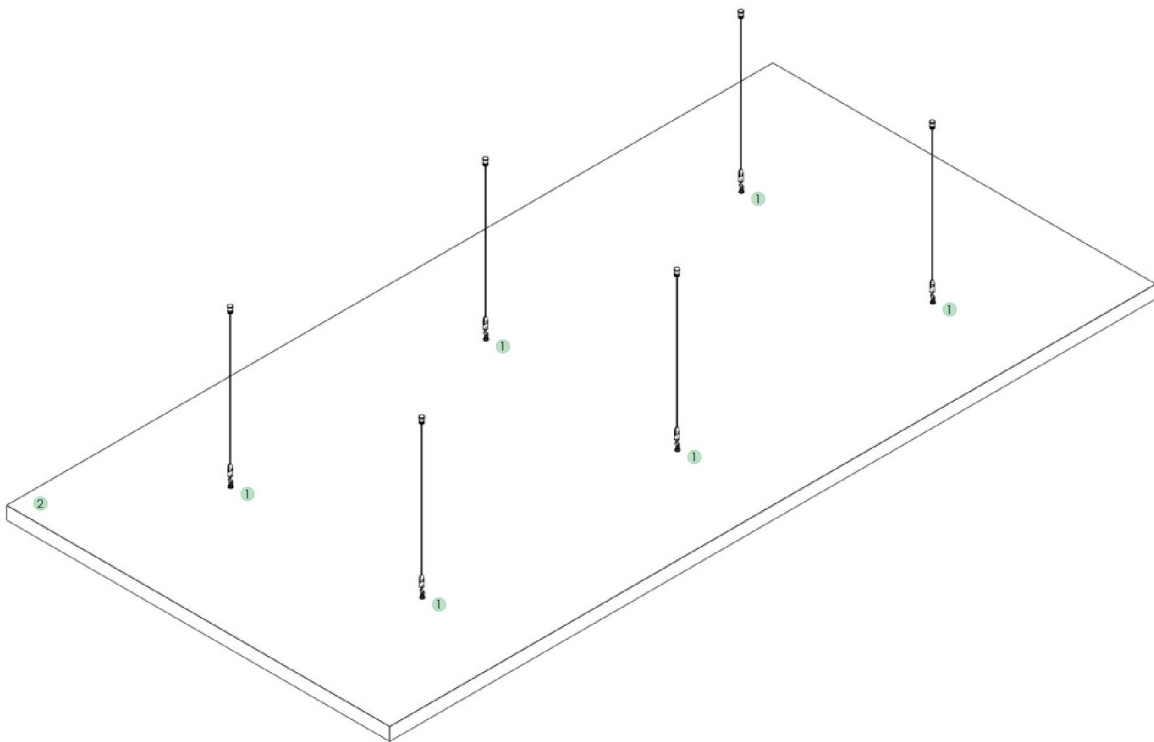

# Reverb Circle

Ceiling Rafts

**Installation Guide** using Spiral Fixing

---

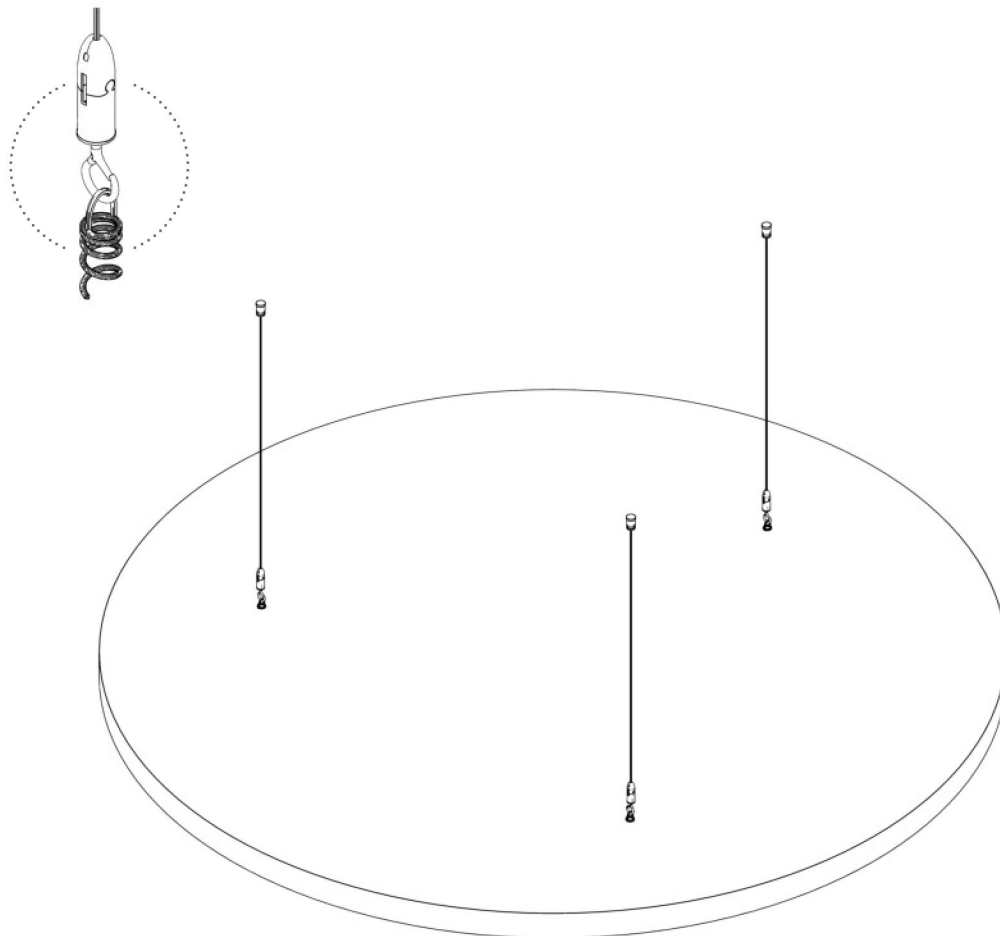

Telford, UK  
Le Lude, FR

+44 (0)1952 947390  
sales@acousticscompany.com

www.acousticscompany.com  
www.acousticscompany.fr

**Design** with confidence  
**Specify** with clarity. p.27

# Reverb Circle

The provided installation guide is intended for general use and is designed to support skilled tradespeople.

---

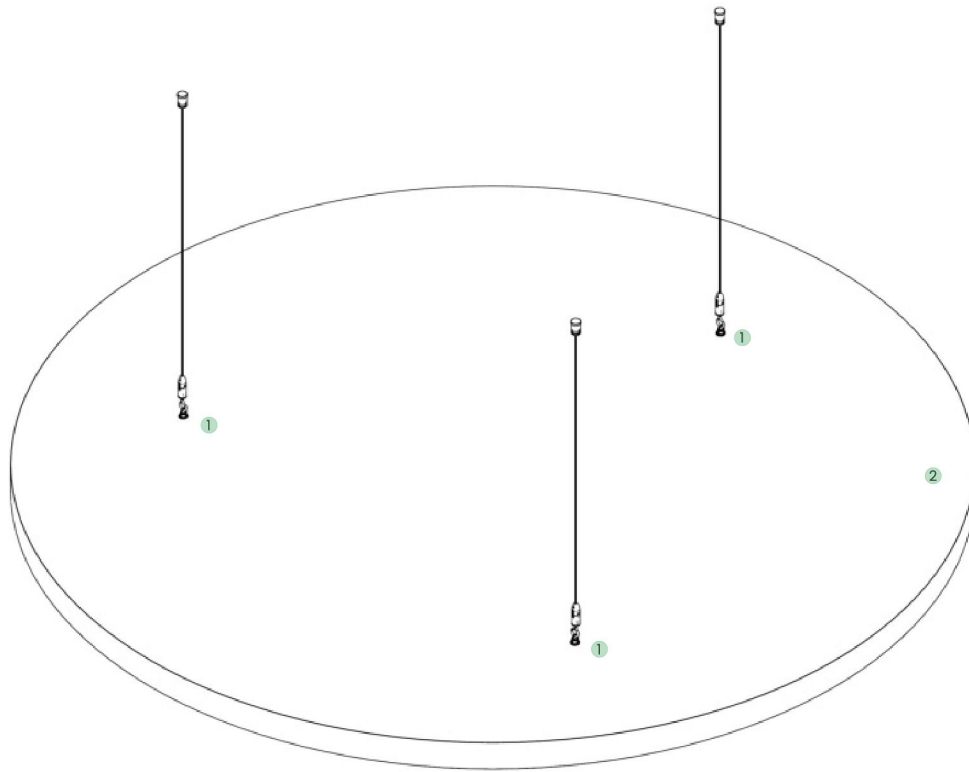

# Reverb Circle

The provided installation guide is intended for general use and is designed to support skilled tradespeople.

---

4

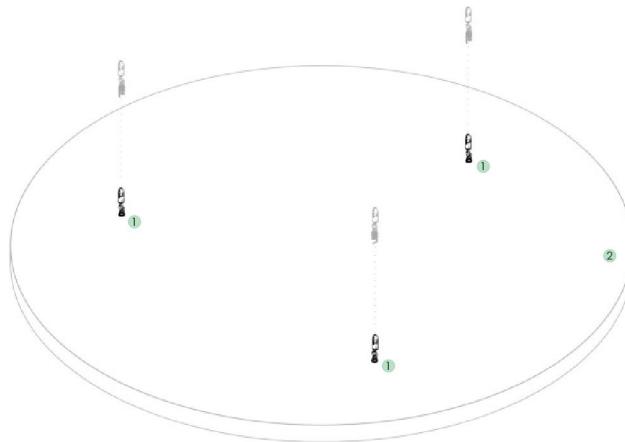

5

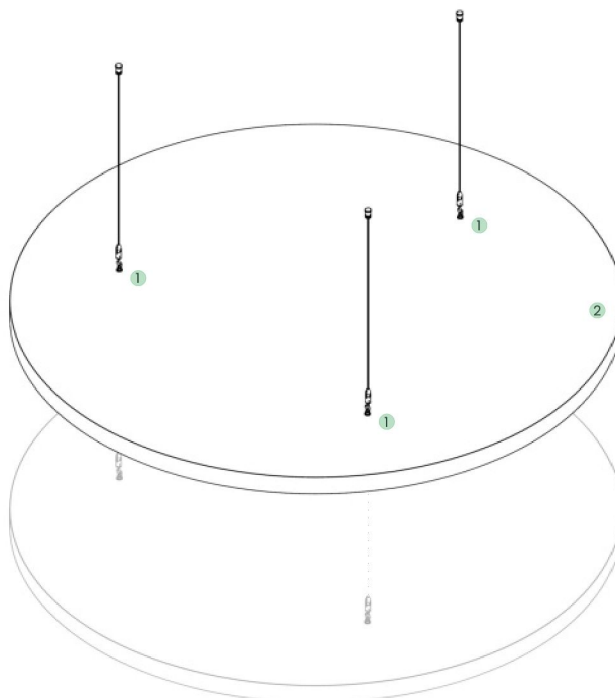

# Reverb Circle

The provided installation guide is intended for general use and is designed to support skilled tradespeople.

---

**2**

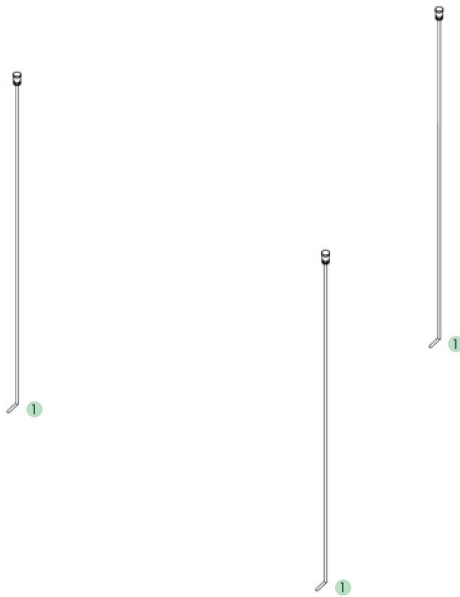

**3**

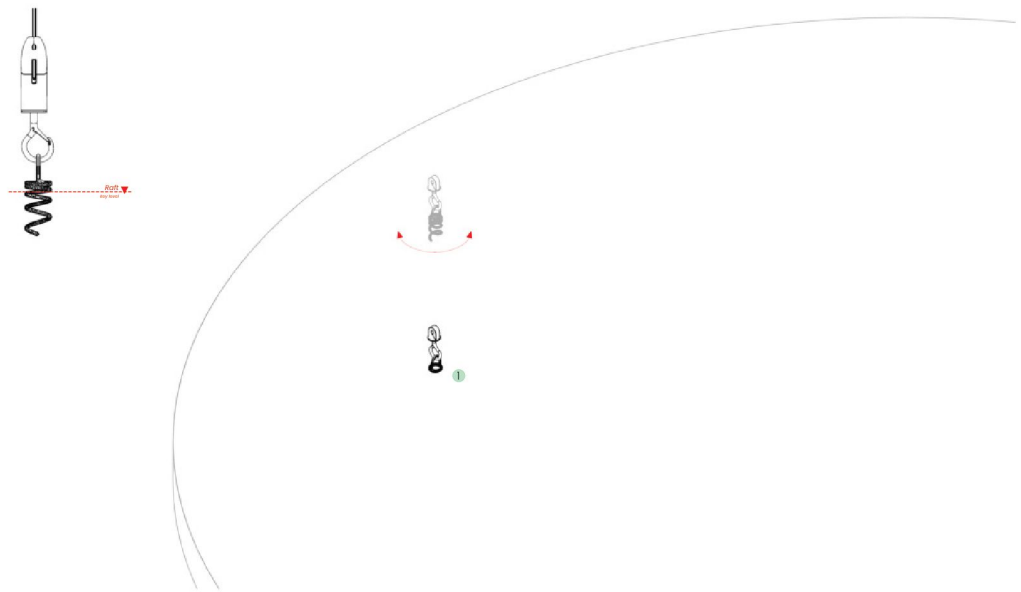

Telford, UK  
Le Lude, FR

+44 (0)1952 947390  
sales@acousticscompany.com

www.acousticscompany.com  
www.acousticscompany.fr

**Design** with confidence  
**Specify** with clarity. p.29

# Reverb Circle

The provided installation guide is intended for general use and is designed to support skilled tradespeople.

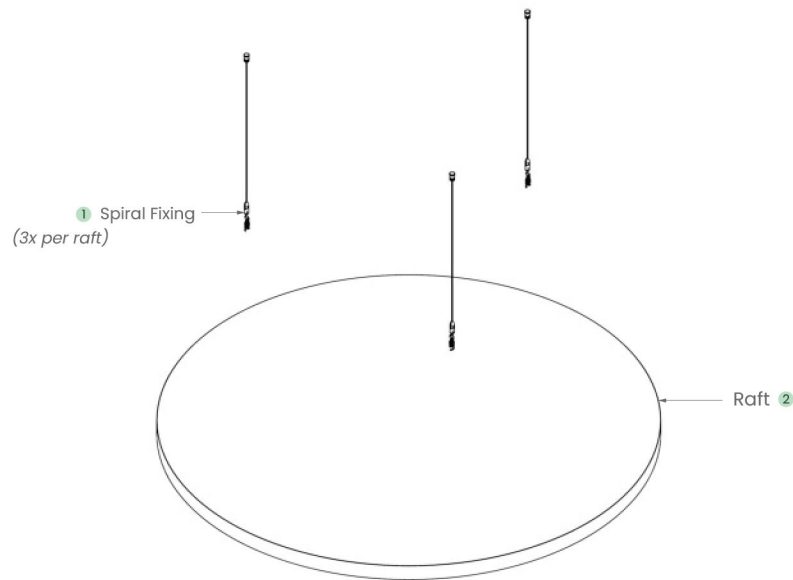

## 1

### Fixing Points

Note: Recommended positions, site specific / additional points to be determined by installer.

### Fixings

Disclaimer: Suitable / additional fixings for substrate to be determined by installer.

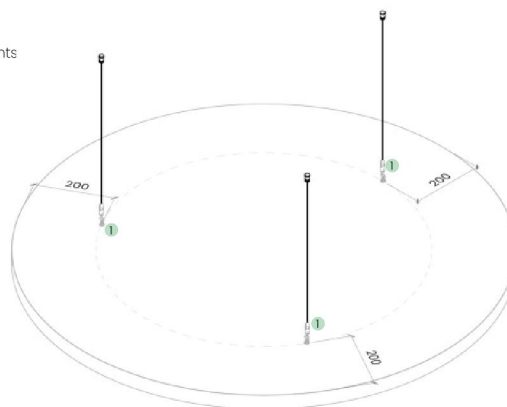

# Reverb Square

The provided installation guide is intended for general use and is designed to support skilled tradespeople.

---

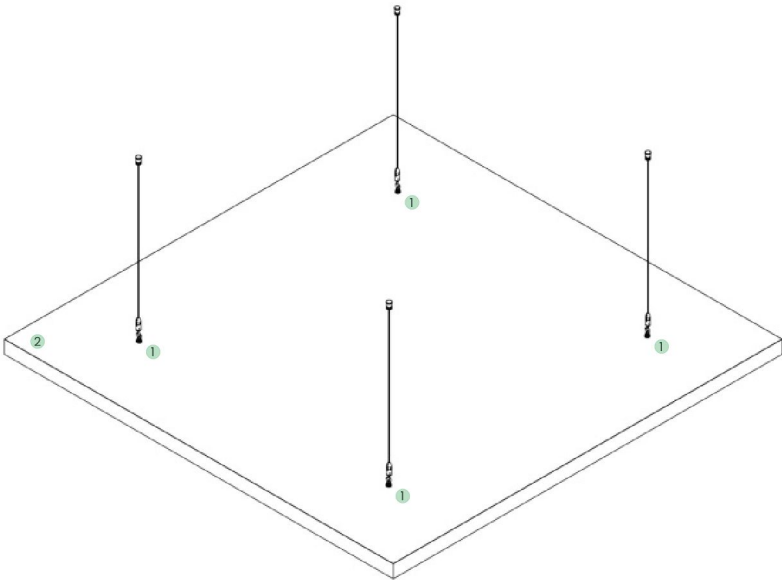

Telford, UK  
Le Lude, FR

+44 (0)1952 947390  
sales@acousticscompany.com

www.acousticscompany.com  
www.acousticscompany.fr

**Design** with confidence  
**Specify** with clarity.

# Reverb Square

The provided installation guide is intended for general use and is designed to support skilled tradespeople.

4

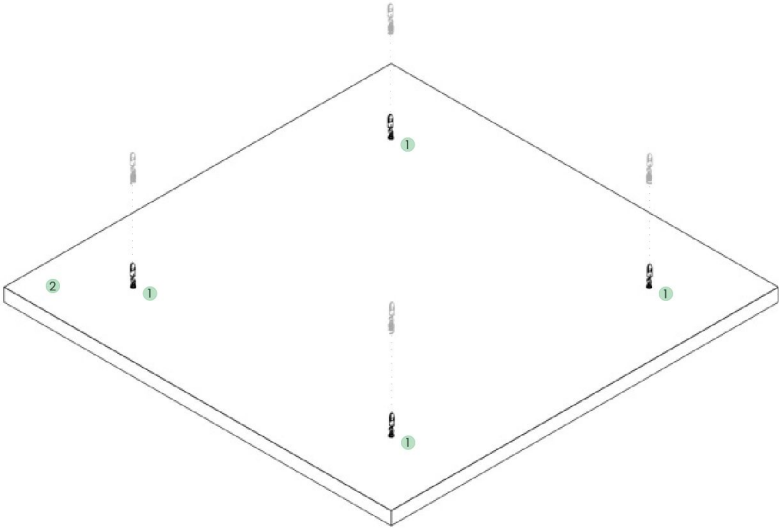

5

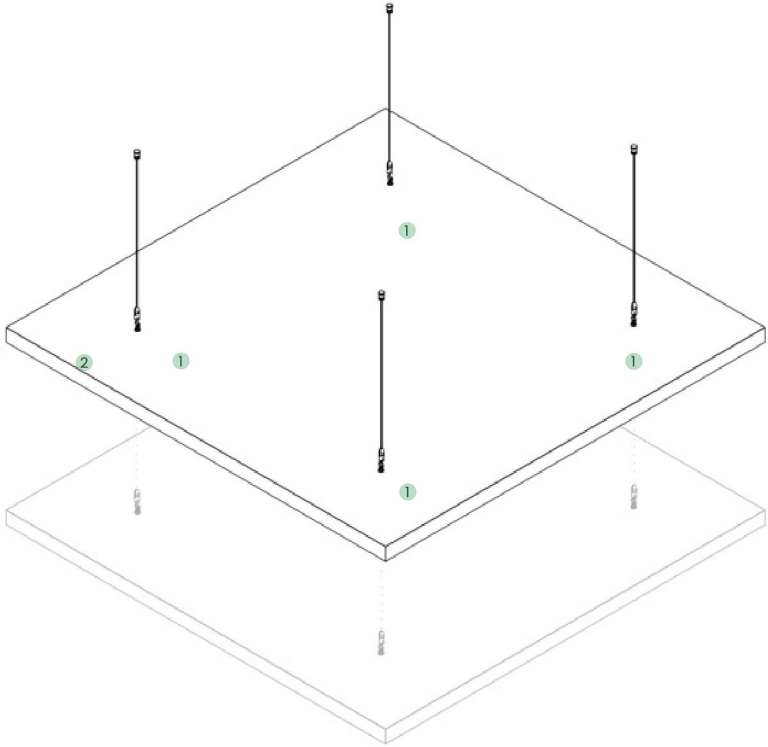

Telford, UK  
Le Lude, FR

+44 (0)1952 947390  
sales@acousticscompany.com

www.acousticscompany.com  
www.acousticscompany.fr

**Design** with confidence  
**Specify** with clarity.

# Reverb Square

The provided installation guide is intended for general use and is designed to support skilled tradespeople.

---

2

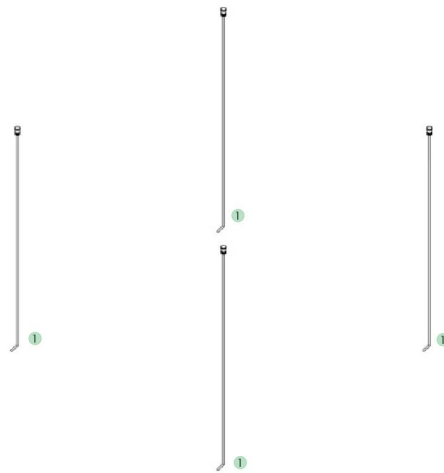

3

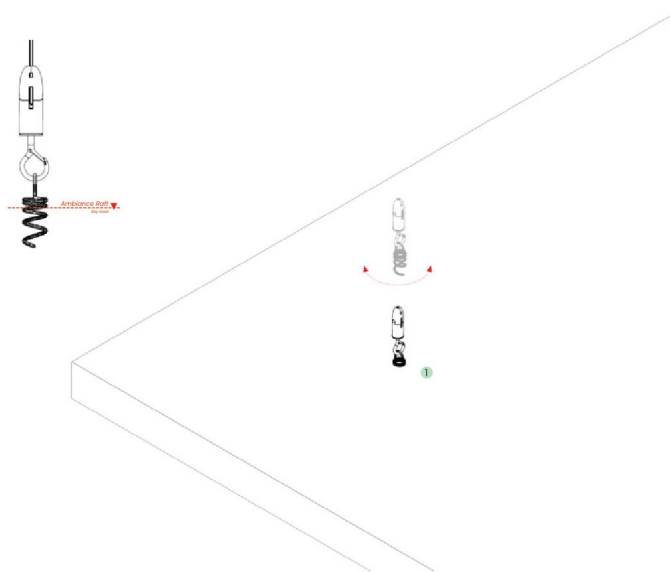

Telford, UK  
Le Lude, FR

+44 (0)1952 947390  
sales@acousticscompany.com

www.acousticscompany.com  
www.acousticscompany.fr

**Design** with confidence  
**Specify** with clarity.

p.34

# Reverb Square

The provided installation guide is intended for general use and is designed to support skilled tradespeople.

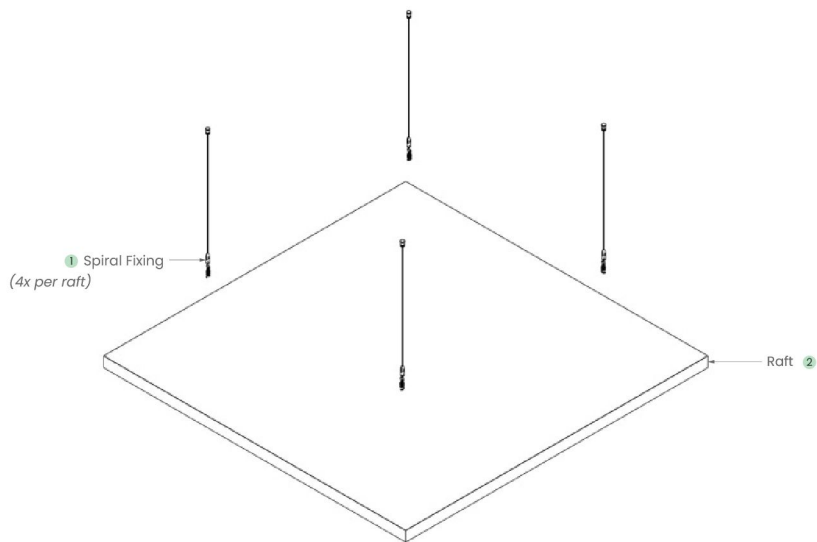

1

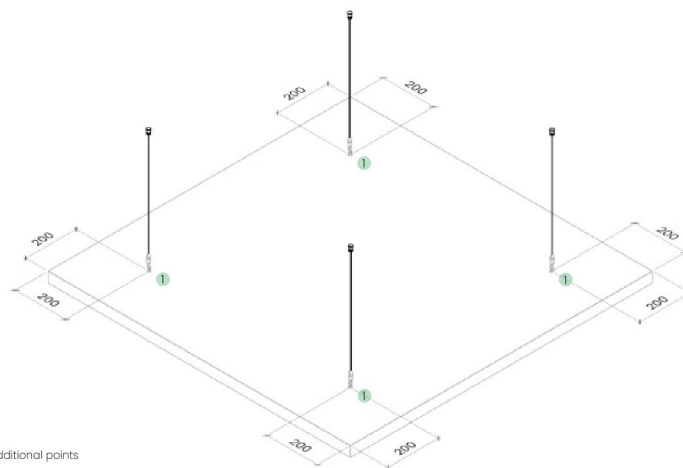

#### Fixing Points

Note: Recommended positions, site specific / additional points to be determined by installer.

#### Fixings

Disclaimer: Suitable / additional fixings for substrate to be determined by installer.



Telford, UK  
Le Lude, FR

+44 (0)1952 947390  
sales@acousticscompany.com

www.acousticscompany.com  
www.acousticscompany.fr

**Design** with confidence  
**Specify** with clarity.

# Reverb Square

Ceiling Rafts

**Installation Guide** using Ambiance Spiral Fixing

---

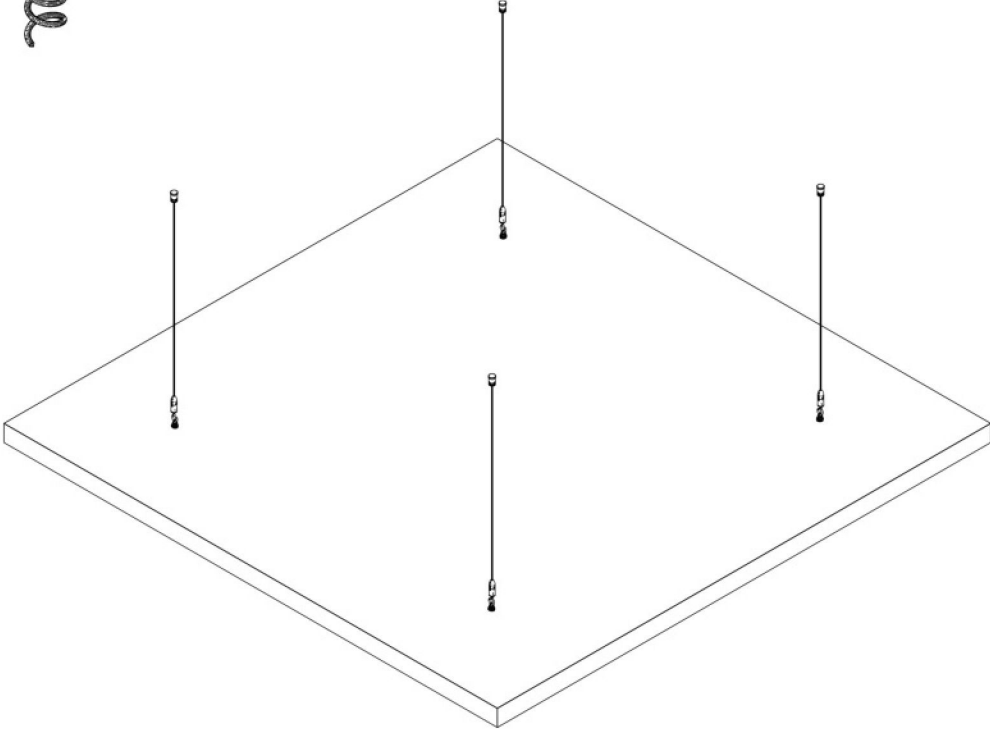
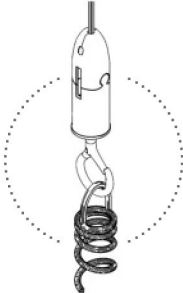

Telford, UK  
Le Lude, FR

+44 (0)1952 947390  
sales@acousticscompany.com

www.acousticscompany.com  
www.acousticscompany.fr

**Design** with confidence  
**Specify** with clarity.

## Disclaimer: Installation Guide



## GENERAL USE, LIABILITY & WARRANTY INFORMATION

---

### INSTALLATION GUIDE DISCLAIMER

Disclaimer: General Guidance Only – Please Read Carefully

This installation guide is provided as a general reference to support the safe and effective installation of our products. It is not intended to replace professional advice or detailed project-specific assessments. While The Acoustics Company has taken care to ensure the accuracy of the information contained herein, we make no representations or warranties regarding its completeness, suitability, or applicability to every project.

### NOT A ONE-SIZE-FITS-ALL SOLUTION

This guide does not account for all possible site conditions, installation environments, or structural considerations. It is the responsibility of the installer, contractor, or project manager to determine whether the guidance provided is suitable for the specific building, substrate, and intended use.

### PROFESSIONAL ASSESSMENT REQUIRED

Installation should only be performed by competent, trained personnel who are familiar with the product, installation techniques, and relevant regulations. If in doubt, always seek advice from a qualified professional or consult with our technical team before proceeding.

### LIABILITY & LIMITATIONS

The Acoustics Company shall not be held liable for any damage, loss, or performance issues resulting from:

- a. Improper installation
- b. Use of unapproved adhesives or fixings
- c. Modification of the product
- d. Failure to verify compatibility with local conditions and regulations

### WARRANTY IMPLICATIONS

Any deviation from the recommended installation procedures may void product warranties. For full details on product warranties, terms of sale, and exclusions, refer to our official documentation.

By using this guide, you acknowledge that it provides general information only and that the final responsibility for product suitability and safe installation lies with the installer or project authority.



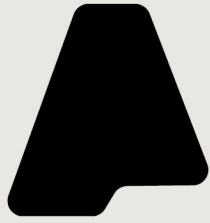

THE  
**ACOUSTICS**  
COMPANY

# Aftercare

# Reverb Panel™

## Care and Maintenance

Caring for Reverb™ panels involves regular dust removal using a soft brush or vacuum with a brush attachment to maintain a clean surface. For marks or light staining, use a damp cloth with a mild detergent solution, ensuring minimal moisture is applied. Avoid harsh chemicals, excessive water, or aggressive cleaning methods. Periodically inspect panels and fixings to ensure continued performance and safety. Proper maintenance will ensure your acoustic rafts maintain both their appearance and acoustic performance over time.

### CLEANING METHODS

- A.** Remove surface dust using a vacuum cleaner with a soft brush attachment.
- B.** Wipe gently with a clean, dry microfiber cloth.
- C.** Lightly wipe with a damp cloth and mild detergent solution. Use minimal moisture and avoid soaking.
- D.** For localised marks, gently dab (do not rub) with a damp cloth and mild detergent.
- E.** Allow panels to dry naturally. Do not apply heat.
- F.** Replace panel if surface is damaged or permanently marked.

### Cleaning guide

Contaminant	Guide
Dust	A
General Dirt	A,C
Light Marks	B,C
Finger Marks	B,C
Surface Debris	A
Scuff Marks	D

Contaminant	Guide
Water-Based Marks	C
Airborn Particles	A,C
Light Staining	D
Minor Surface Marks	B,C



## **Recommended Application & Maintenance Guidance**

- Gloves must always be worn when handling panels to prevent marking or surface damage
- Suitable for use in dry internal environments only
- Avoid installation or cleaning in high humidity conditions
- Ensure fixings are checked periodically for safety and stability
- Panels should be handled carefully to avoid edge or surface damage

## **IMPORTANT NOTES**

- Do not use abrasive cleaners or solvents
- Do not saturate panels with water
- Avoid scrubbing or applying pressure to the surface
- Always clean gently to maintain finish and acoustic performance



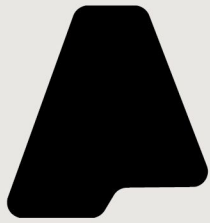

THE  
**ACOUSTICS**  
COMPANY



# REVERB

*Designed to integrate seamlessly within architectural environments, Reverb delivers high-performance acoustic control with clarity in specification and confidence in delivery.*

**Copyright © 2026 The Acoustics Company. All Rights Reserved.**

This document and its contents are the property of The Acoustics Company. Prepared to support confident design decisions and clear specification, this guide is intended for reference, coordination, and early-stage planning only. No part of this document may be copied, reproduced, edited, cropped, extracted, or distributed, in whole or in part, without prior written permission from The Acoustics Company. All information should be reviewed and verified against project-specific conditions, site coordination requirements, and final approved drawings prior to specification, manufacture, or installation.



Telford, UK  
Le Lude, FR

+44 (0)1952 947390  
sales@acousticscompany.com

www.acousticscompany.com  
www.acousticscompany.fr

**Design** with confidence  
**Specify** with clarity. p.41